

GENERAC®

Owner's Manual
For
Automatic Transfer Switch

85 Amp

Model Number
RXG16EZA1

MODEL NUMBER: _____

SERIAL NUMBER: _____

DATE PURCHASED: _____

WWW.GENERAC.COM
1-888-GENERAC
(1-888-436-3722)



Para español, visita: <http://www.generac.com/service-support/product-support-lookup>

Pour le français, visiter : <http://www.generac.com/service-support/product-support-lookup>

SAVE THIS MANUAL FOR FUTURE REFERENCE

 **WARNING**

CANCER AND REPRODUCTIVE HARM

www.P65Warnings.ca.gov

(000393a)

Table of Contents

Section 1: Introduction and Safety

Introduction	1
Read This Manual Thoroughly	1
Safety Rules	1
Safety Symbols and Meanings	2
General Hazards	3

Section 2: General Information

Unpacking	5
Contents in Loose Parts Bag	5
Equipment Description	5
Transfer Switch Mechanism	5
Circuit Breakers Listed for Use	6
Transfer Switch Data Decal	6
Transfer Switch Enclosure	6
Safe Use of Transfer Switch	6
Load Management Options	6

Section 3: Installation

Mounting the Transfer Switch	7
Mounting the Outdoor Connection Box	7
Routing the Flexible Conduit	8
Connecting Power Source and Load Lines	8
Connecting Start Circuit Wires	9
Installing Branch Circuit Conductors – USA Installations	10
Installing Branch Circuit Conductors – Canadian Installations	10
Installing Breakers	11

Section 4: Operation

Functional Tests and Adjustments	13
Manual Operation	13
Transfer Mechanism Manual Operation	13
Close to Generator Source Side	14
Return to Utility Source Side	14
Voltage Checks	14
Utility Voltage Checks	14
Generator Voltage Checks	14
Generator Tests Under Load	14
Checking Automatic Operation	15
Installation Summary	15
Shutting Generator Down While Under Load	15
Fuse Removal and Installation	16

Section 5: Drawings and Diagrams

Installation Drawing (USA)	17
Installation Drawing (Canada)	18
Wiring Diagram	19
Wiring Diagram	20
Schematic Diagram	21

This page intentionally left blank.

Section 1: Introduction and Safety

Introduction

Thank you for purchasing a Generac Power Systems Inc. product. This unit has been designed to provide high performance, efficient operation, and years of use when maintained properly. This transfer switch is listed with ETL under UL1008 standard.

Read This Manual Thoroughly



WARNING

Consult Manual. Read and understand manual completely before using product. Failure to completely understand manual and product could result in death or serious injury. (000100a)

If any section of this manual is not understood, contact the nearest Independent Authorized Service Dealer (IASD) or Generac Customer Service at 1-888-436-3722 (1-888-GENERAC), or visit www.generac.com for starting, operating, and servicing procedures. The owner is responsible for proper maintenance and safe use of the unit.

SAVE THESE INSTRUCTIONS for future reference. This manual contains important instructions that must be followed during placement, operation, and maintenance of the unit and its components. Always supply this manual to any individual that will use this unit, and instruct them on how to correctly start, operate, and stop the unit in case of emergency.

Safety Rules

The manufacturer cannot anticipate every possible circumstance that might involve a hazard. The alerts in this manual, and on tags and decals affixed to the unit, are not all inclusive. If using a procedure, work method, or operating technique that the manufacturer does not specifically recommend, verify that it is safe for others and does not render the equipment unsafe.

Throughout this publication, and on tags and decals affixed to the unit, DANGER, WARNING, CAUTION, and NOTE blocks are used to alert personnel to special instructions about a particular operation that may be hazardous if performed incorrectly or carelessly. Observe them carefully. Alert definitions are as follows:

DANGER

Indicates a hazardous situation which, if not avoided, will result in death or serious injury.

(000001)

WARNING

Indicates a hazardous situation which, if not avoided, could result in death or serious injury.

(000002)

CAUTION

Indicates a hazardous situation which, if not avoided, could result in minor or moderate injury.

(000003)

NOTE: Notes contain additional information important to a procedure and will be found within the regular text of this manual.

These safety alerts cannot eliminate the hazards that they indicate. Common sense and strict compliance with the special instructions while performing the action or service are essential to preventing accidents.

Safety Symbols and Meanings



⚠ DANGER

Electrocution. High voltage is present at transfer switch and terminals. Contact with live terminals will result in death or serious injury.

(000129)



⚠ DANGER

Electrocution. Water contact with a power source, if not avoided, will result in death or serious injury.

(000104)



⚠ DANGER

Electrocution. In the event of electrical accident, immediately shut power OFF. Use non-conductive implements to free victim from live conductor. Apply first aid and get medical help. Failure to do so will result in death or serious injury.

(000145)

⚠ DANGER

Electrical backfeed. Use only approved switchgear to isolate generator from the normal power source. Failure to do so will result in death, serious injury, and equipment damage.

(000237)



⚠ DANGER

Electrocution, equipment and property damage. Handle transfer switches carefully when installing. Never install a damaged transfer switch. Doing so could result in death or serious injury, equipment and property damage.

(000195)



⚠ DANGER

Electrocution. Turn utility supply OFF before working on utility connections of the transfer switch. Failure to do so will result in death or serious injury.

(000123)



⚠ DANGER

Electrocution. Do not disable or modify the connection box door safety switch. Doing so will result in death or serious injury.

(000157)

⚠ DANGER

Automatic start-up. Disconnect utility power and render unit inoperable before working on unit. Failure to do so will result in death or serious injury.

(000191)

⚠ DANGER

Equipment malfunction. Installing a dirty or damaged transfer switch will cause equipment malfunction and will result in death or serious injury.

(000119)

⚠ WARNING

Electric shock. Only a trained and licensed electrician should perform wiring and connections to unit. Failure to follow proper installation requirements could result in death, serious injury, and equipment or property damage.

(000155a)

⚠ CAUTION

Equipment damage. Verify all conductors are tightened to the factory specified torque value. Failure to do so could result in damage to the switch base.

(000120)

⚠ CAUTION

Equipment damage. Perform functional tests in the exact order they are presented in the manual. Failure to do so could result in equipment damage.

(000121)

⚠ CAUTION

Equipment damage. Exceeding rated voltage and current will damage the auxiliary contacts. Verify that voltage and current are within specification before energizing this equipment.

(000134a)

General Hazards

⚠ DANGER

Electrical backfeed. Use only approved switchgear to isolate generator from the normal power source. Failure to do so will result in death, serious injury, and equipment damage.

(000237)



⚠ DANGER

Electrocution. High voltage is present at transfer switch and terminals. Contact with live terminals will result in death or serious injury.

(000129)



⚠ DANGER

Electrocution. Turn utility supply OFF before working on utility connections of the transfer switch. Failure to do so will result in death or serious injury.

(000123)



⚠ DANGER

Electrocution. Water contact with a power source, if not avoided, will result in death or serious injury.

(000104)



⚠ DANGER

Electrocution. Do not wear jewelry while working on this equipment. Doing so will result in death or serious injury.

(000188)



⚠ DANGER

Electrocution. Only authorized personnel should access transfer switch interior. Transfer switch doors should be kept closed and locked. Failure to do so will result in death or serious injury.

(000213)

⚠ DANGER

Automatic start-up. Disconnect utility power and render unit inoperable before working on unit. Failure to do so will result in death or serious injury.

(000191)



⚠ DANGER

Electrocution. In the event of electrical accident, immediately shut power OFF. Use non-conductive implements to free victim from live conductor. Apply first aid and get medical help. Failure to do so will result in death or serious injury.

(000145)

⚠ WARNING

Sudden start-up. Always set the safety disconnect switch to MANUAL before working on equipment. Failure to do so could result in death or serious injury.

(000194)

- Competent, qualified personnel should install, operate and service this equipment. Adhere strictly to local, state and national electrical and building codes. When using this equipment, comply with regulations established by the National Electrical Code (NEC), CSA Standard; C22.1 Canadian Electric Code, the Occupational Safety and Health Administration (OSHA), and the local agency for workplace health and safety.
- If working on this equipment while standing on metal or concrete, place insulative mats over a dry wood platform. Work on this equipment only while standing on such insulative mats.
- Never work on this equipment while physically or mentally fatigued.
- Any voltage measurements should be performed with a meter that meets UL3111 safety standards, and meets or exceeds overvoltage class CAT III.

This page intentionally left blank.

Section 2: General Information

Unpacking

Carefully unpack the transfer switch. Inspect closely for any damage that might have occurred during shipment. The purchaser must file with the carrier any claims for loss or damage incurred while in transit.

Check that all packing material is completely removed from the switch prior to installation.

The pre-wired switch includes:

- 30 foot, five foot, and two foot (9.1 m, 1.5 m, and 0.61 m) pre-wired conduits for making all required wiring runs.
- An outdoor junction box for making connections between outdoor and indoor pre-wired conduits.
- UL listed wire nuts for reconnecting standby circuits within the main distribution panel.

The pre-wired limited circuit automatic transfer switch can be installed along with an 8, 11, or 16 kW Air-cooled Standby Generator, or can be used to pre-wire a home or small business in advance of generator installation. In either case, the provided wiring saves installation time and cost, since the majority of labor involved in installing a standby power system is in wiring the generator, automatic transfer switch and standby circuit subpanel.

Contents in Loose Parts Bag

- Owner's manual
- Warranty statement
- Manual operating handle
- Storage bracket for manual operating handle
- Fault current label
- Clear decal for fault current label

Equipment Description

The automatic transfer switch is used for transferring electrical load from a UTILITY (NORMAL) power source to a GENERATOR (STANDBY) power source. Such a transfer of electrical loads occurs automatically when the UTILITY power source has failed or is substantially reduced and the GENERATOR source voltage and frequency have reached an acceptable level. The transfer switch prevents electrical feedback between two different power sources (such as the UTILITY and GENERATOR sources) and, for that reason, codes require it in all standby electric system installations.

The transfer switch consists of a transfer mechanism, a control relay, fuses, terminal strip, and fuse holder for connection of sensing wires.

The transfer switch is listed for use on optional standby systems only (NEC 702).

Transfer Switch Mechanism

These switches (*Figure 2-1*) are used with a single-phase system, when the single-phase NEUTRAL line is to be connected to a neutral lug and is not to be switched.

Solderless, screw-type terminal lugs are standard.

The conductor size range is as follows:

Switch Rating	Wire Range	Conductor Tightening Torque	Lug Temp. Rating
100A	#14-1/0 AWG (Cu/Al)	50 in-lbs (5.6 Nm)	167°F (75°C)

This transfer switch is suitable for control of motors, electric discharge lamps, tungsten filament, and electric heating equipment where the sum of motor full load ampere ratings and the ampere ratings of other loads do not exceed the ampere rating of the switch and the tungsten load does not exceed 30 percent of the switch rating.

This transfer switch is suitable for use on a circuit capable of 10,000 symmetrical amperes, 240 VAC maximum. The transfer switch is rated at 85 Amperes.

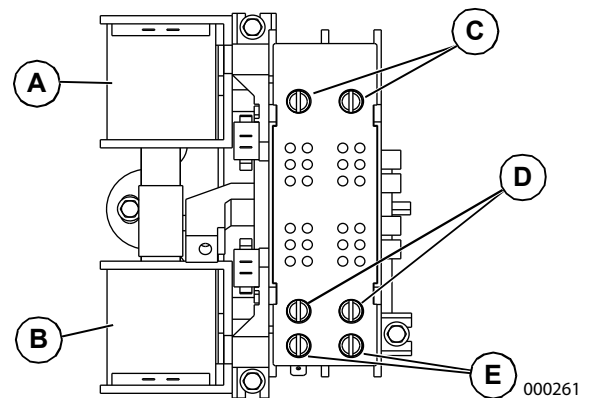

Figure 2-1. Typical Single-Phase ATS Transfer Mechanism

A	Utility Closing Coil
B	Generator Closing Coil
C	Utility Lugs (N1 & N2)
D	Generator Lugs (E1 & E2)
E	Load Lugs (T1 & T2)

Circuit Breakers Listed for Use

This switch is listed for use with the following one inch breakers:

- Siemens*
- Murray*
- Eaton
- Square D

*Including GFCI, AFCI and tandem breakers up to 50 amps.

NOTE: For branch circuits over 50 amps, only listed Siemens or Murray circuit breakers (RXG16EZ only) shall be used.

Transfer Switch Data Decal

A data decal is permanently affixed to the transfer switch enclosure. Use this transfer switch only with the specific limits shown on the data decal and on other decals and labels that may be affixed to the switch. This will prevent damage to equipment and property.

When requesting information or ordering parts for this equipment, make sure to include all information from the data decal.

For future reference, record the Model and Serial numbers in the space provided on the front cover of this manual.

Transfer Switch Enclosure

The standard switch enclosure is a National Electrical Manufacturer's Association (NEMA) 1 type, rated for indoor use only.

Safe Use of Transfer Switch



WARNING

Consult Manual. Read and understand manual completely before using product. Failure to completely understand manual and product could result in death or serious injury. (000100a)

Before installing, operating or servicing this equipment, read the **Safety Rules** carefully. Comply strictly with all **Safety Rules** to prevent accidents and/or damage to the equipment. The manufacturer recommends that a copy of the **Safety Rules** be posted near the transfer switch. Also, be sure to read all instructions and information found on tags, labels, and decals affixed to the equipment.

Publications that outline the safe installation and manufacturing of transfer switches are the following:

- NFPA 70; National Electrical Code
- UL 1008, STANDARD FOR SAFETY-AUTOMATIC TRANSFER SWITCHES
- UL67; Panel boards

NOTE: It is essential to use the latest version of any standard to ensure correct and current information.

Load Management Options

Loads can be managed using a smart power management system. The system can accommodate up to eight individual Smart Management Modules (SMM).*

NOTE: The SMM modules are self-contained and have individual built-in controllers.

***See SMM Module (available separately)**

Section 3: Installation

Mounting the Transfer Switch



⚠ DANGER

Electrocution. Turn utility supply OFF before working on utility connections of the transfer switch. Failure to do so will result in death or serious injury. (000123)

⚠ DANGER

Equipment malfunction. Installing a dirty or damaged transfer switch will cause equipment malfunction and will result in death or serious injury. (000119)

⚠ WARNING

Equipment damage. Only qualified service personnel may install, operate, and maintain this equipment. Failure to follow proper installation requirements could result in death, serious injury, and equipment or property damage. (000182a)

Mounting dimensions for the transfer switch enclosure are in this manual. Enclosures are typically wall-mounted. See the [Drawings and Diagrams](#) section.

This transfer switch is mounted in a NEMA 1 enclosure. It can be mounted indoors only and should be based on the layout of installation, convenience and proximity to the utility supply and load center.

IMPORTANT: Always adhere to local electrical codes during installation.

1. Locate transfer switch where the proper equipment and clear working space can be maintained.
2. Hold transfer switch against the mounting surface.

IMPORTANT: To eliminate the possibility of debris contamination, never drill inside the enclosure.

3. Drill the appropriate size holes for mounting hardware at marked hole locations.
4. Mount transfer switch to mounting surface with appropriate fasteners.

NOTE: The two foot (0.61 m) whip and conduit can be installed on either side of the box through a removable plate.

NOTE: Transfer switch must be mounted vertically as shown in [Figure 3-1](#).

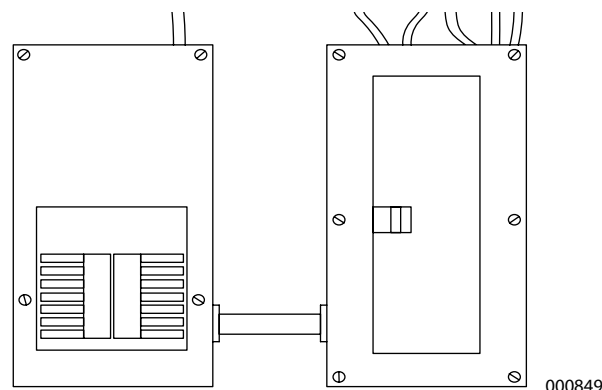

Figure 3-1. Transfer Switch Mounting

Mounting the Outdoor Connection Box

1. Lift cover.
2. Remove internal cover plate screw and internal cover.
3. Remove the knock out in the lower right corner of the external connection box and feed wires, 4-pin and 2-pin plugs into box.
4. Slip the lock nut over wires and plugs and tighten securely onto conduit coupling.
5. Using appropriate fasteners, mount external connection box over area where conduits will enter through the back of the box.
6. Connect wires to lugs; black to black, white to white, and red to red.
7. Tighten screws to 35 in-lbs (4 Nm).
8. Snap together the 4-pin and 2-pin plug connector.
9. Terminate grounding electrode conductor to the equipment grounding terminal.
10. Tighten lug to specification below.

Ground Lug Torque Specifications

45 in-lbs (5 Nm)	No. 4–6 AWG
40 in-lbs (4.5 Nm)	No. 8 AWG
35 in-lbs (4 Nm)	No. 10–14 AWG

11. Close cover.



⚠ DANGER

Electrocution. Do not disable or modify the connection box door safety switch. Doing so will result in death or serious injury. (000157)

(000157)

Routing the Flexible Conduit

1. Determine where the flexible conduit will pass through the building from inside to outside.
2. While adhering to all local electrical codes, route the 30 foot (9.1 m) conduit along ceiling/floor joists and wall studs to the location where the conduit will pass through the wall to the exterior of the building.

NOTE: The 30 foot (9.1 m) whip can be shortened to any length or lengthened up to 70 additional feet (21.3 m). It can also be removed and replaced with field wiring.

NOTE: The two foot pre-wire whip can be shortened if needed or removed and replaced with field wiring. The factory installed branch circuits and circuit breakers can also be modified if needed. Follow all applicable electrical codes for any field modification.

IMPORTANT: Follow all applicable NEC codes for the installed wiring methods.

3. From inside the building, feed the end of the 30-foot (9.1 m) conduit (INCLUDED and pre-wired from transfer switch) through the wall to the outside.
4. Remove the threaded lock nut from the conduit connector.

Connecting Power Source and Load Lines



⚠ DANGER

Electrocution. Turn utility and emergency power supplies to OFF before connecting power source and load lines. Failure to do so will result in death or serious injury. (000116)

Installation and interconnection diagrams are provided in the [Drawings and Diagrams](#) section of this manual.

NOTE: All installations must comply with national, state and local codes. It is the responsibility of the installer to perform an installation that will pass the final electrical inspection.

The utility supply, generator, and customer load connections are made at the transfer switch mechanism, inside the switch enclosure.

Conductor sizes must be adequate to handle the maximum current to which they will be subjected, based on the 75°C column of tables, charts, etc. used to size conductors. The installation must comply fully with all applicable codes, standards, and regulations.

NOTE: If aluminum conductors are used, apply corrosion inhibitor to conductors. After tightening terminal lugs, carefully wipe away any excess corrosion inhibitor.

Tighten terminal lugs to the torque values as noted on the inside of the door. (See [Table 3-1: Terminal Tightening Torque.](#))

⚠ CAUTION

Equipment damage. Verify all conductors are tightened to the factory specified torque value. Failure to do so could result in damage to the switch base.

(000120)

Connect power source and load conductors to clearly marked terminal lugs on transfer mechanism as follows:

1. Install a 70 Amp double-pole breaker for 11-16kW units, in the home's main distribution panel. This will be the utility (normal) power source for transfer switch.
2. Customer LOAD leads are pre-wired at the factory.

NOTE: Conductors must be properly supported, of approved insulative qualities, protected by approved conduit, and of the correct wire gauge size in accordance with applicable codes.

Table 3-1. Terminal Tightening Torque

Terminal	Wire Size	Torque
Switch Contactor	1/0-14 CU / 1/0-12 AL	50 in-lbs
Neutral	10-14 CU / 10-12 AL	20 in-lbs
	8 AWG	25 in-lbs
	6-4 AWG	35 in-lbs
Control Wiring		11 in-lbs

Connecting Start Circuit Wires

Control system interconnections consist of N1, N2, and T1, and leads 23, 194, and 0 (see [Figure 3-2](#)).

NOTE: To simplify installation, Generac Composite Tray Cable control wiring color codes match the label on the control module.

The generator control wiring is a Class 1 signaling circuit. Reference instruction manual of specific engine generator for wiring connection details. Screw heads are straight bladed and cross-bladed, and should be tightened to 3.5 in-lb (0.4 Nm).

Recommended wire gauge is No. 18 AWG.

Exception: Conductors of AC and DC circuits, rated 1000 volts nominal, or less, shall be permitted to occupy the same equipment, cable, or conduit. All conductors shall have an insulation rating equal to at least the maximum circuit voltage applied to any conductor within the equipment, cable, or conduit. See NEC 300.3(C)(1).

Terminal Numbering Decal	Wire Numbers
BLUE*	T1—Fused 120 VAC for battery charger
YELLOW	N1—Fused 240 VAC Sensing for utility dropout and pickup
YELLOW WITH BLACK STRIPE	N2—Fused 240 VAC Sensing for utility dropout and pickup
BLACK	0—DC (-) Not required
RED	194—DC (+) 12 VDC for transfer controls
WHITE	23—Transfer control signal wire

* Required to supply utility or generator voltage to the generator battery charger.

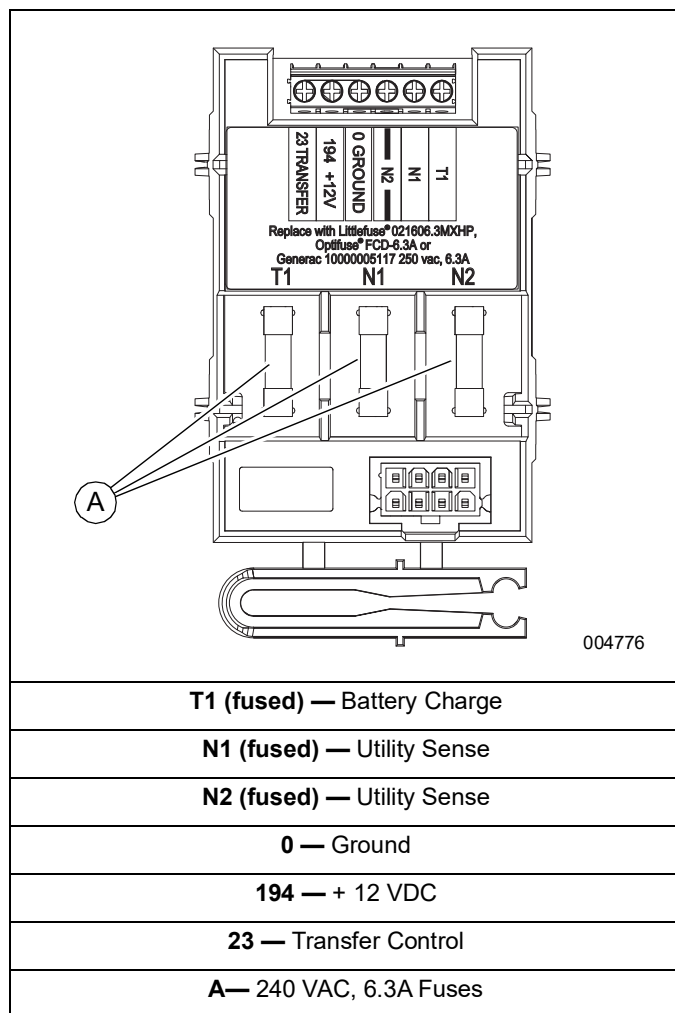

Figure 3-2. Typical Connections

Installing Branch Circuit Conductors – USA Installations

1. Select which branch circuits will be protected by the generator in the normal power panel board.
2. Turn the circuit breaker in the normal power panel board to the off position.
3. Remove the ungrounded (hot) conductor from the circuit breaker and neutral conductor from the neutral terminal bar in the normal power panel board.

NOTE: Multi-wire branch circuits must be connected to circuit breakers that are adjacent to each other. If the circuit to be protected is part of a multi-wire branch circuit, the entire multi-wire branch circuit must be relocated to the transfer switch panel board (See NEC 210.4). The branch circuit wiring can be removed from the normal power panel board and installed in the transfer switch panel board, or spliced onto new branch circuit wiring originating from the transfer switch panel board.

4. If the normal power panel board is being used as a junction box for the protected branch circuit conductors, install the two foot (0.61 m) conduit, raceway(s), or other approved wiring method between the transfer switch panel board and normal power panel board.
5. Install properly sized branch circuit conductors between the transfer switch panel board to the branch circuit conductors to be protected by the transfer switch, if not using factory supplied wiring.
6. Use listed wire nuts or any other approved termination device to connect the branch circuit conductors.
7. Install the provided label on the existing panel board that indicates the location of the disconnecting means for the pass through conductors.
8. If the generator protected branch circuit conductors are being re-installed into the transfer switch panel board, punch the required sized hole(s) for the cable, conduit, or raceway.
9. Route the branch circuit conductors into the transfer switch and terminate the equipment ground conductor on the equipment ground terminal bar, the neutral on the neutral terminal bar, and the ungrounded (hot) on the circuit breaker terminal.
10. Size all conductors, raceways, conduits, and junction boxes, if required, to the applicable NEC code articles and follow the NEC installation requirements for the wiring method(s) selected.

NOTE: The two foot (0.61 m) pre-wired whip can be shortened if needed or removed and replaced with field wiring. The factory installed branch circuits and circuit breakers can also be modified if needed. Follow all applicable electrical codes for any field modification.

Installing Branch Circuit Conductors – Canadian Installations

1. Select which branch circuits will be protected by the generator in the normal power panel board. Turn the circuit breaker in the normal power panel board to the off position.
2. Remove the ungrounded (hot) conductor from the circuit breaker and neutral conductor from the neutral terminal bar in the normal power panel board.

NOTE: If the circuit to be protected is part of a multi-wire branch circuit, the entire multi-wire branch circuit must be relocated to the transfer switch panel board.

3. The Canadian Electric Code prohibits the use of the normal power panel board as a junction box, the generator protected branch circuit wiring must be relocated to a properly sized junction box, or reinstalled into the transfer switch panel board.
4. Punch the required sized hole(s) for the cable, conduit, or raceway into the transfer switch.
5. Route the branch circuit conductors into the transfer switch and terminate the equipment ground conductor on the equipment ground terminal bar, the neutral on the neutral terminal bar, and the ungrounded (hot) on the circuit breaker terminal.
6. Size all conductors, raceways, conduits, and junction boxes, if required, to the applicable CEC code articles and follow the CEC installation requirements for the wiring method(s) selected.

NOTE: The two foot (0.61 m) pre-wired whip can be shortened if needed or removed and replaced with field wiring. The factory installed branch circuits and circuit breakers can also be modified if needed. Follow all applicable electrical codes for any field modification.

Installing Breakers

IMPORTANT: AFCI and GFCI circuit breakers are not provided by the factory. If the circuits to be protected require AFCI or GFCI protection, or both, then listed protection shall be provided by the installer.

The factory supplied breakers can be changed by the installer. Install listed and labeled circuit breakers that are compatible with the transfer switch (See [Circuit Breakers Listed for Use](#)). Follow all applicable NEC and CEC code articles for any field modifications.

Insert the tab on the breaker (A) into the hook on the bus (B). Push the breaker into the bus until it snaps into place.

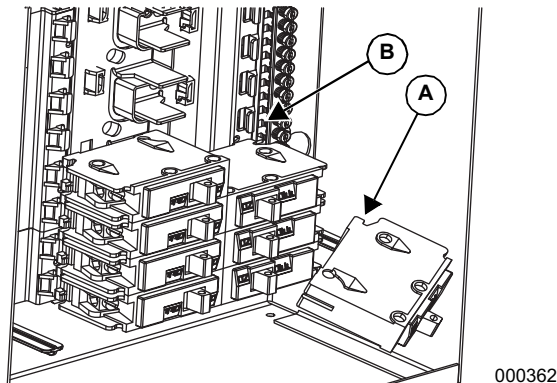

Figure 3-3. Installing Breakers

This page intentionally left blank.

Section 4: Operation

Functional Tests and Adjustments

Following transfer switch installation and interconnection, inspect the entire installation carefully. A competent, qualified electrician should inspect it. The installation should comply strictly with all applicable codes, standards, and regulations. When absolutely certain the installation is proper and correct, complete a functional test of the system.



Equipment damage. Perform functional tests in the exact order they are presented in the manual. Failure to do so could result in equipment damage.

(000121)

IMPORTANT: Before proceeding with functional tests, read and make sure all instructions and information in this section is understood. Also read the information and instructions of labels and decals affixed to the switch. Note any options or accessories that might be installed and review their operation.

Manual Operation



Electrocution. Do not manually transfer under load. Disconnect transfer switch from all power sources prior to manual transfer. Failure to do so will result in death or serious injury, and equipment damage.

(000132)

The transfer switch is equipped with a manual operating handle.

See [Figure 4-1](#). Manual operation must be checked BEFORE the transfer switch is operated electrically.

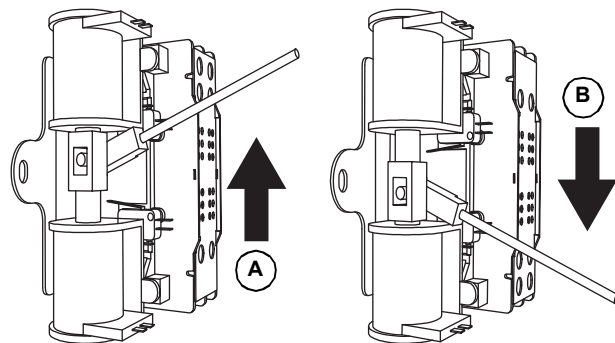

000260

Figure 4-1. Transfer Mechanism Manual Operation

A	Utility Position
B	Generator Position

To check manual operation, proceed as follows:

1. Verify the generator is OFF.
 2. Turn OFF both UTILITY (service disconnect circuit breaker) and STANDBY (generator main line circuit breaker) power supplies to the transfer switch.
 3. Note position of transfer mechanism main contacts by observing the movable contact carrier arm. This can be viewed through the long narrow slot in the inside cover of the ATS. The top of the movable contact carrier arm is yellow to be easily identified.
- Manual operation handle in the UP position—LOAD terminals (T1, T2) are connected to UTILITY terminals (N1, N2).
 - Manual operation handle in the DOWN position—LOAD terminals (T1, T2) are connected to STANDBY terminals (E1, E2).



Equipment damage. Do not use excessive force while manually operating the transfer switch. Doing so could result in equipment damage.

(000122)

Transfer Mechanism Manual Operation

Before proceeding, verify the position of the switch by observing the position of manual operation handle in [Figure 4-1](#). If the handle is UP, the contacts are closed in the NORMAL (UTILITY) position, no further action is required. If the handle is DOWN, proceed with Step 1.

1. With the handle inserted into the movable contact carrier arm, move handle UP. Be sure to hold on to the handle as it will move quickly after the center of travel.
2. Remove manual operating handle from movable contact carrier arm. Return handle to storage bracket.

Close to Generator Source Side

Before proceeding, verify the position of the switch by observing the position of the manual operation handle in [Figure 4-1](#). If the handle is DOWN, the contacts are closed in the GENERATOR (STANDBY) position. No further action is required. If the handle is UP, proceed with Step 1.

1. With the handle inserted into the movable contact carrier arm, move the handle DOWN. Be sure to hold on to the handle as it will move quickly after the center of travel.
2. Remove manual operating handle from movable contact carrier arm. Return handle to storage bracket.

Return to Utility Source Side

1. Manually actuate switch to return manual operating handle to the UP position.
2. Remove manual operating handle from movable contact carrier arm. Return handle to storage bracket.

Voltage Checks

NOTE: Use the Digital Multimeter (DMM) LowZ low input impedance setting to collect accurate voltage measurements. LowZ eliminates the possibility of inaccurate ghost voltage readings, also known as phantom voltage or stray voltage readings. See DMM manufacturer’s literature for additional information.

Utility Voltage Checks



⚠ DANGER

Electrocution. High voltage is present at transfer switch and terminals. Contact with live terminals will result in death or serious injury.

(000129)



⚠ DANGER

Electrocution. Turn utility supply OFF before working on utility connections of the transfer switch. Failure to do so will result in death or serious injury.

(000123)

1. Turn ON the UTILITY power supply to the transfer switch using the breaker in main distribution panel.
2. With an accurate AC voltmeter, check for correct voltage. Measure across ATS terminal lugs N1 and N2; N1 to NEUTRAL and N2 to NEUTRAL.

Generator Voltage Checks



⚠ DANGER

Electrocution. High voltage is present at transfer switch and terminals. Contact with live terminals will result in death or serious injury.

(000129)

1. On the generator panel, select the MANUAL mode of operation. The generator should crank and start.
2. Let the generator stabilize and warm up at no-load for at least five minutes.
3. Set the generator's main circuit breaker (CB1) to its ON or CLOSED position.
4. With an accurate AC voltmeter and frequency meter, check the no-load, voltage and frequency. Measure across ATS terminal lugs E1 to E2; E1 to NEUTRAL and E2 to NEUTRAL.

Frequency	60-62 Hz
Terminals E1 to E2	240-246 VAC
Terminals E1 to NEUTRAL	120-123 VAC
Terminals E2 to NEUTRAL	120-123 VAC

5. When certain that generator supply voltage is correct and compatible with transfer switch ratings, turn OFF the generator supply to the transfer switch.
6. Set the generator main circuit breaker (CB1) to OFF or OPEN.
7. On the generator panel, select the OFF mode to shut down the generator.

NOTE: Do NOT proceed until generator AC output voltage and frequency are correct and within stated limits.

Generator Tests Under Load

1. Set the generator main circuit breaker to OFF or OPEN.
2. Set the utility service disconnect circuit breaker to OFF or OPEN.
3. Manually actuate the transfer switch main contacts to the Standby position. See [Manual Operation](#).
4. To start the generator, select the MANUAL mode of operation. When engine starts, let it stabilize for a few minutes.
5. Set the generator main circuit breaker to ON or CLOSED. The generator now powers all LOAD circuits. Check generator operation under load as follows:
 - Turn on electrical loads to the full rated wattage/ amperage capacity of the generator. DO NOT OVERLOAD.

- With maximum rated load applied, check voltage and frequency across transfer switch terminals E1 and E2. Voltage should be greater than 230 VAC (240 VAC system); frequency should be greater than 59 Hz.
 - Verify that the gas pressure remains within acceptable parameters (see the generator Installation Guidelines manual).
 - Let the generator run under rated load for at least 30 minutes. With unit running, listen for unusual noises, vibration, overheating, etc., that might indicate a problem.
6. When checkout under load is complete, set main circuit breaker of the generator to the OFF or OPEN position.
 7. Let the generator run at no-load for several minutes. Then, shut down by selecting the OFF mode.
 8. Move the main switch contacts back to the utility position.
 9. Place the manual handle in its storage bracket.

NOTE: See [Manual Operation](#). Handle and operating lever of transfer switch should be in up position.

10. Turn ON the utility power supply to transfer switch, using whatever means provided (such as a utility main line circuit breaker). The utility power source now powers the loads.
11. The system is now set for fully automatic operation.

Checking Automatic Operation

To check the system for proper automatic operation, proceed as follows:

1. Verify generator is OFF.
2. Verify switch is de-energized.
3. Install front cover of the transfer switch.
4. Turn the utility power supply to the transfer switch ON, using the utility main line circuit breaker.
5. Set the generator main circuit breaker to ON.
6. On the generator panel, select AUTO. The system is now ready for automatic operation.
7. Turn utility power supply to the transfer switch OFF.

With the generator ready for automatic operation, the engine should crank and start when the utility source power is turned OFF after a ten second delay (factory default setting). After starting, the transfer switch should connect load circuits to the standby side after the engine warm-up delay. Let the system operate through its entire automatic sequence of operation.

With the generator running and loads powered by generator AC output, turn ON the utility power supply to the transfer switch. The following should occur:

- After approximately 15 seconds, the switch should transfer loads back to the utility power source.

- Approximately one minute after re-transfer, the engine should shut down.

With the generator in the AUTOMATIC mode, the system is now set for fully automatic operation.

Installation Summary

1. Verify the installation has been properly performed as outlined by the manufacturer and that it meets all applicable laws and codes.
2. Verify proper operation of the system as outlined in the appropriate installation and owner's manuals.
3. Educate the end-user on the proper operation, maintenance, and service call procedures.

Shutting Generator Down While Under Load

IMPORTANT: To turn the generator off during utility outages to perform maintenance, or conserve fuel, follow these important steps:

To turn the generator OFF (while running in AUTO and Online):

1. Turn the main utility disconnect OFF.
2. Turn the main line circuit breaker (MLCB) on the generator to OFF (OPEN).
3. Allow the generator to run at least one minute to cool down.
4. Turn the generator OFF.

NOTE: If turning the unit off for longer than 24 hours, remove the F1 fuse from the generator controller.

To turn the generator back ON:

1. Reinstall F1 fuse if necessary.
2. Put the generator back into AUTO and allow to start and warm-up for a few minutes.
3. Set the MLCB on the generator to On.

The system will now be operating in automatic mode. The main utility disconnect can be turned ON (CLOSED).

NOTE: To shut the unit off, this complete process must be repeated.

Fuse Removal and Installation

See [Figure 4-2](#). A fuse removal and installation tool (A) is included in the control housing.

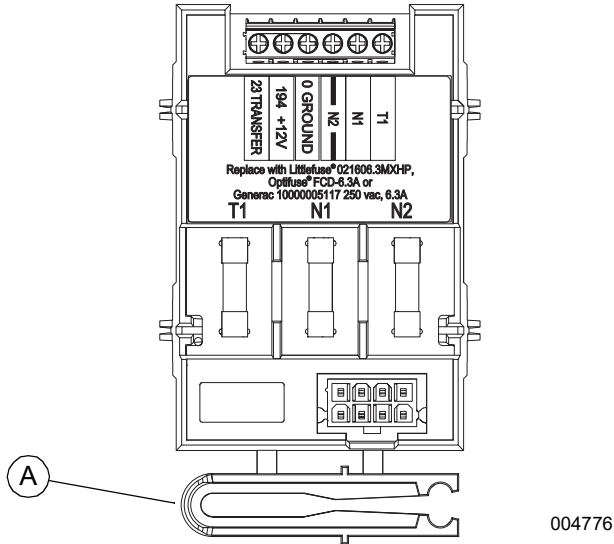

Figure 4-2. Fuse Removal and Installation Tool

If a fuse requires replacement, snap the tool free with an appropriate tool such as diagonal pliers, and use it to replace the fuse. The tool can be stored in the control housing retainer directly above the fuses, with the large thumb tab facing out.

Use only Generac replacement fuses—part number 10000005117, rated 240 VAC, 6.3 Amps, 10,000 AIC.

Alternative fuses are Littelfuse® 021606.3MXHP or Optifuse® FCD-6.3.

Section 5: Drawings and Diagrams

Installation Drawing (USA)

No. 10000017887 (Part 1 of 2)

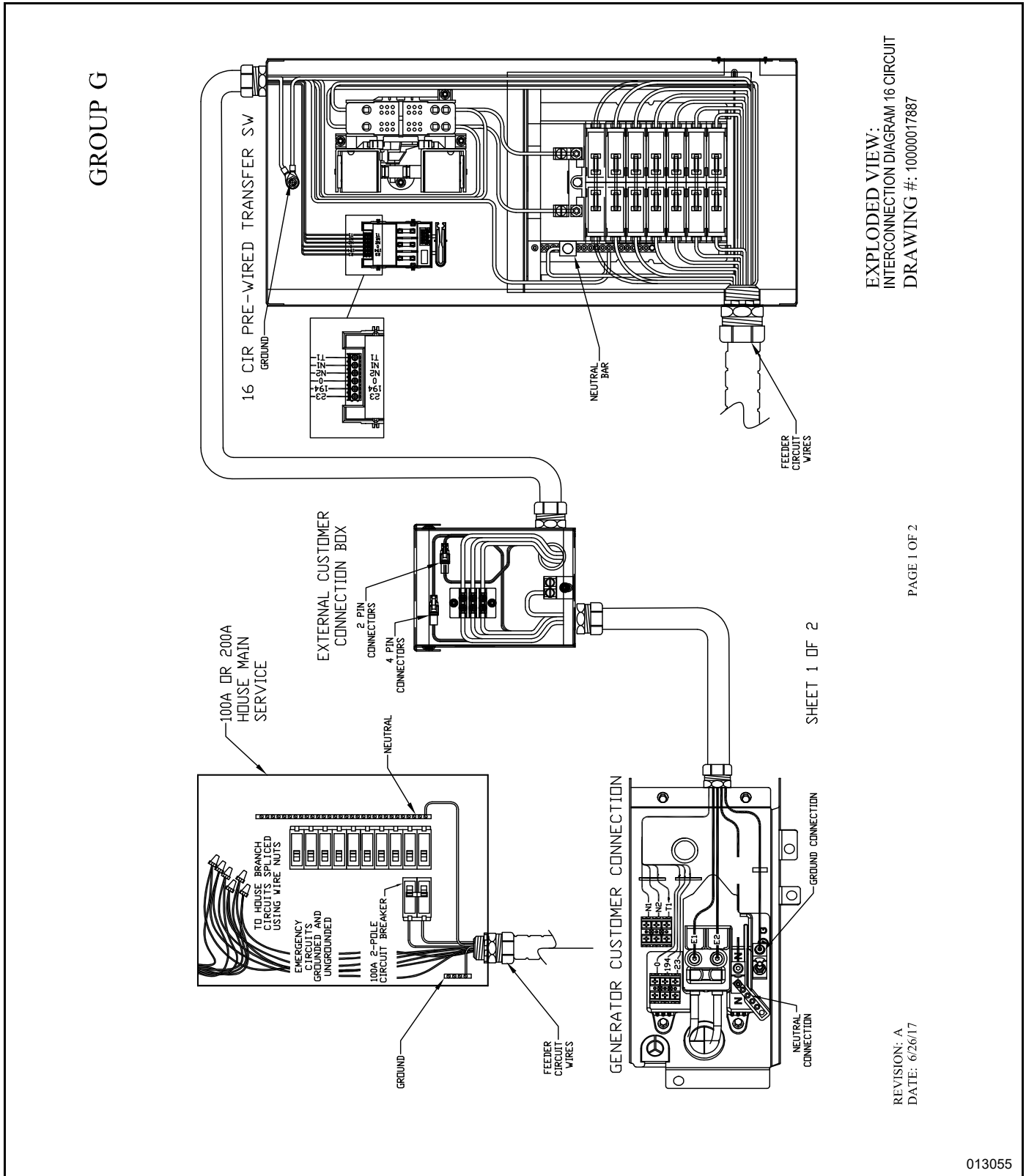

EXPLODED VIEW:
INTERCONNECTION DIAGRAM 16 CIRCUIT
DRAWING #: 10000017887

PAGE 1 OF 2

SHEET 1 OF 2

REVISION: A
DATE: 6/26/17

013055

Installation Drawing (Canada)

No. 10000017887 (Part 2 of 2)

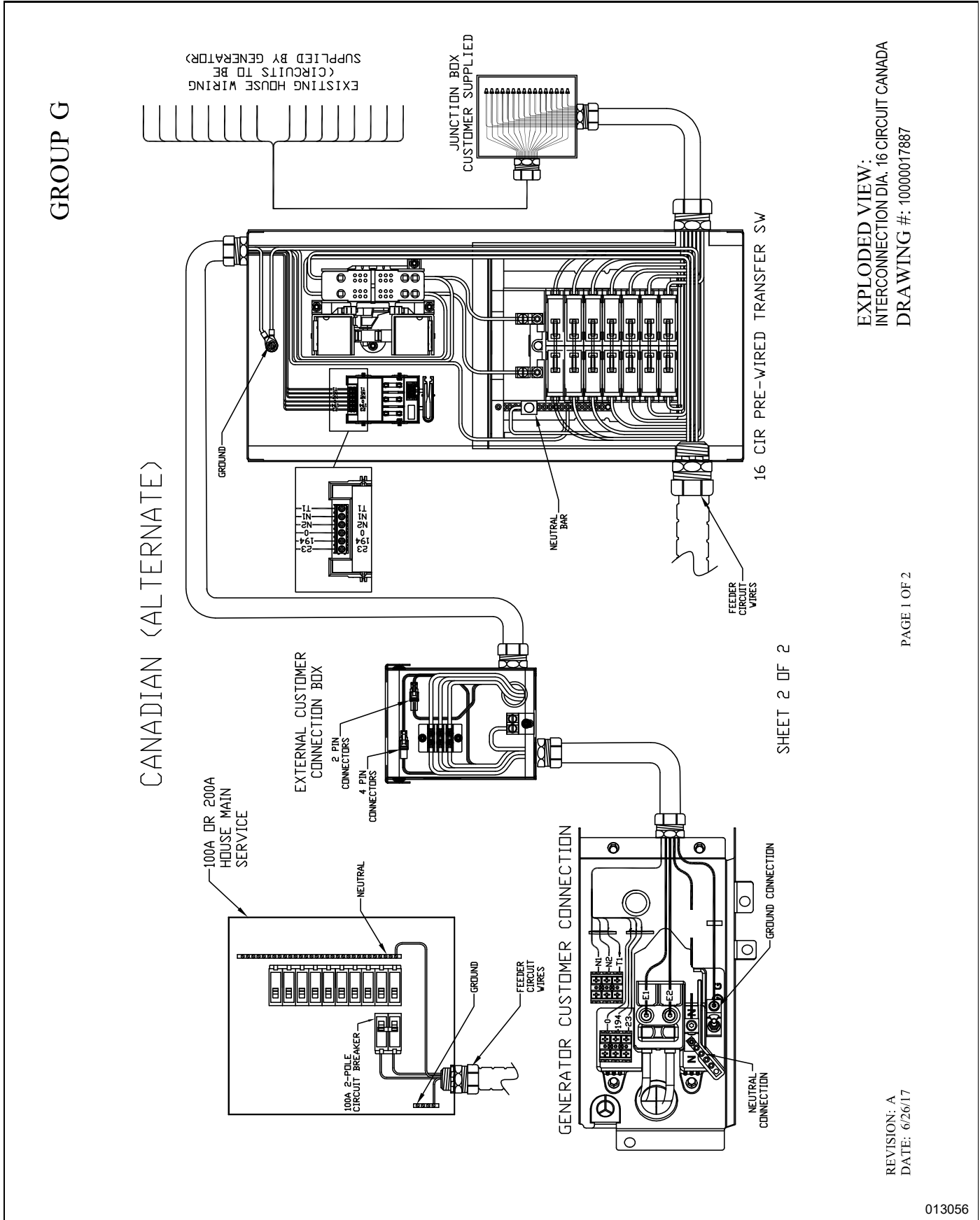

EXPLODED VIEW:
INTERCONNECTION DIA. 16 CIRCUIT CANADA
DRAWING #: 10000017887

PAGE 1 OF 2

SHEET 2 OF 2

REVISION: A
DATE: 6/26/17

013056

Wiring Diagram

No. 10000019053 (Part 1 of 2)

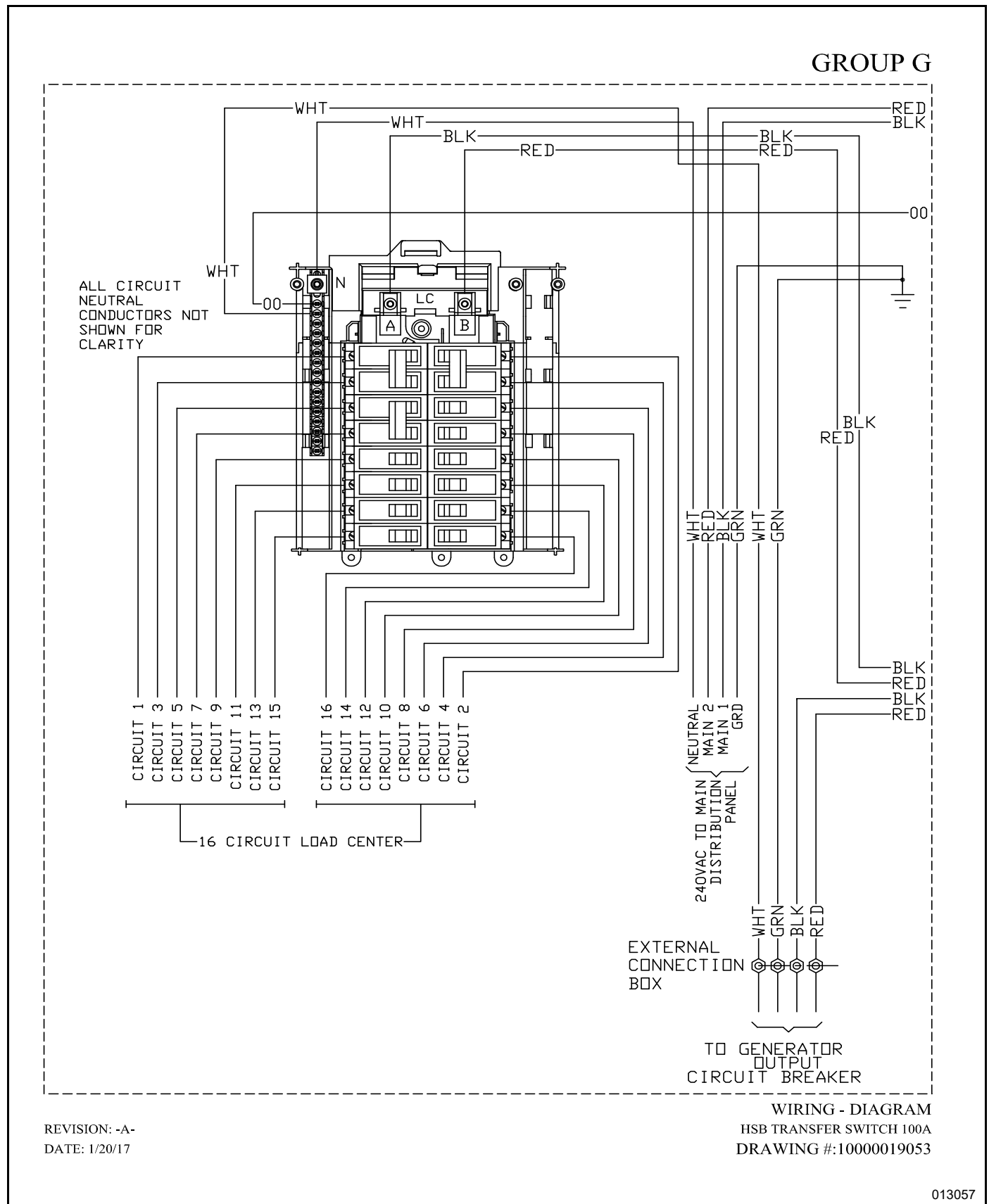

REVISION: -A-
DATE: 1/20/17

013057

Wiring Diagram

No. 10000019053 (Part 2 of 2)

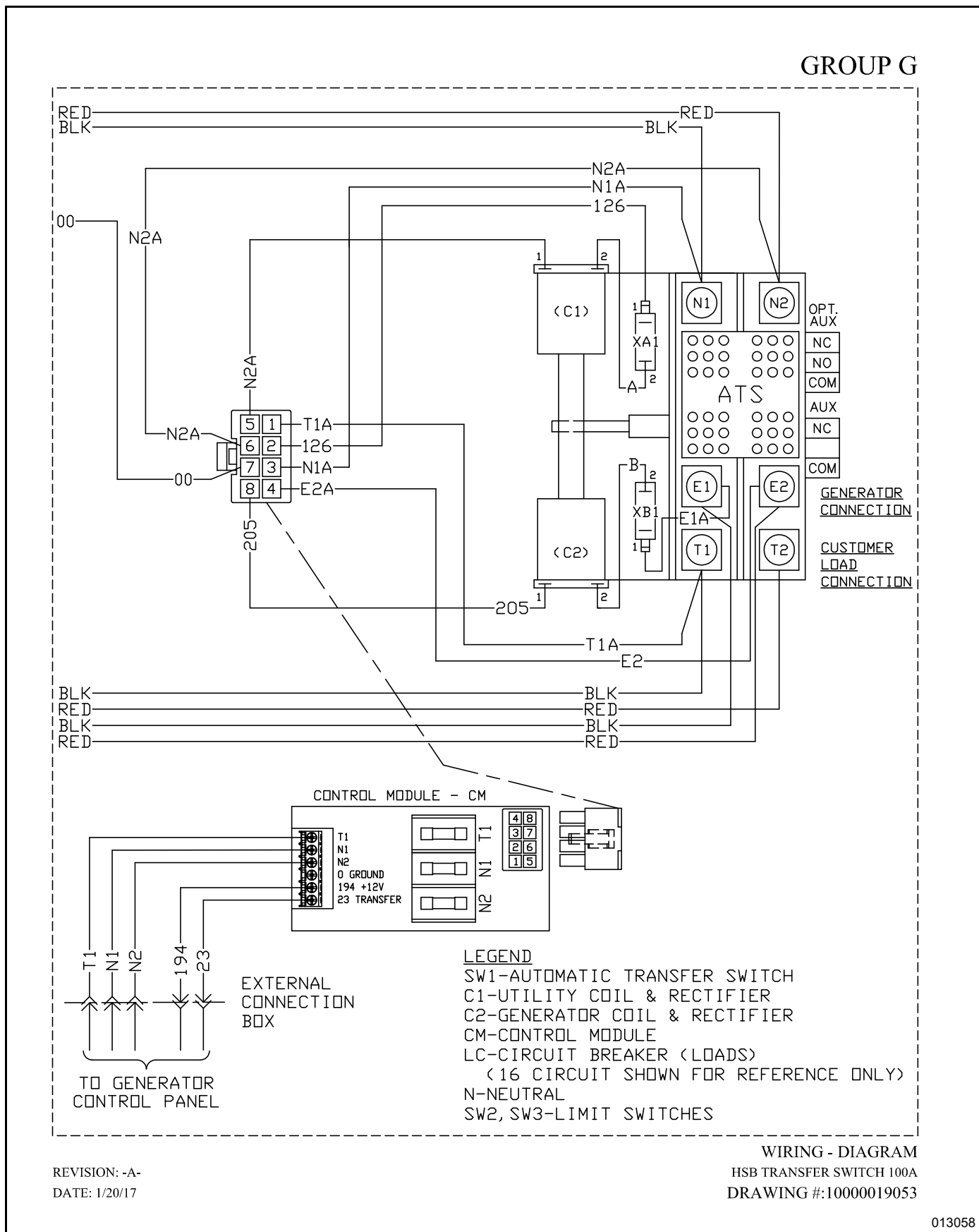

Schematic Diagram

No. 10000018987

GROUP G

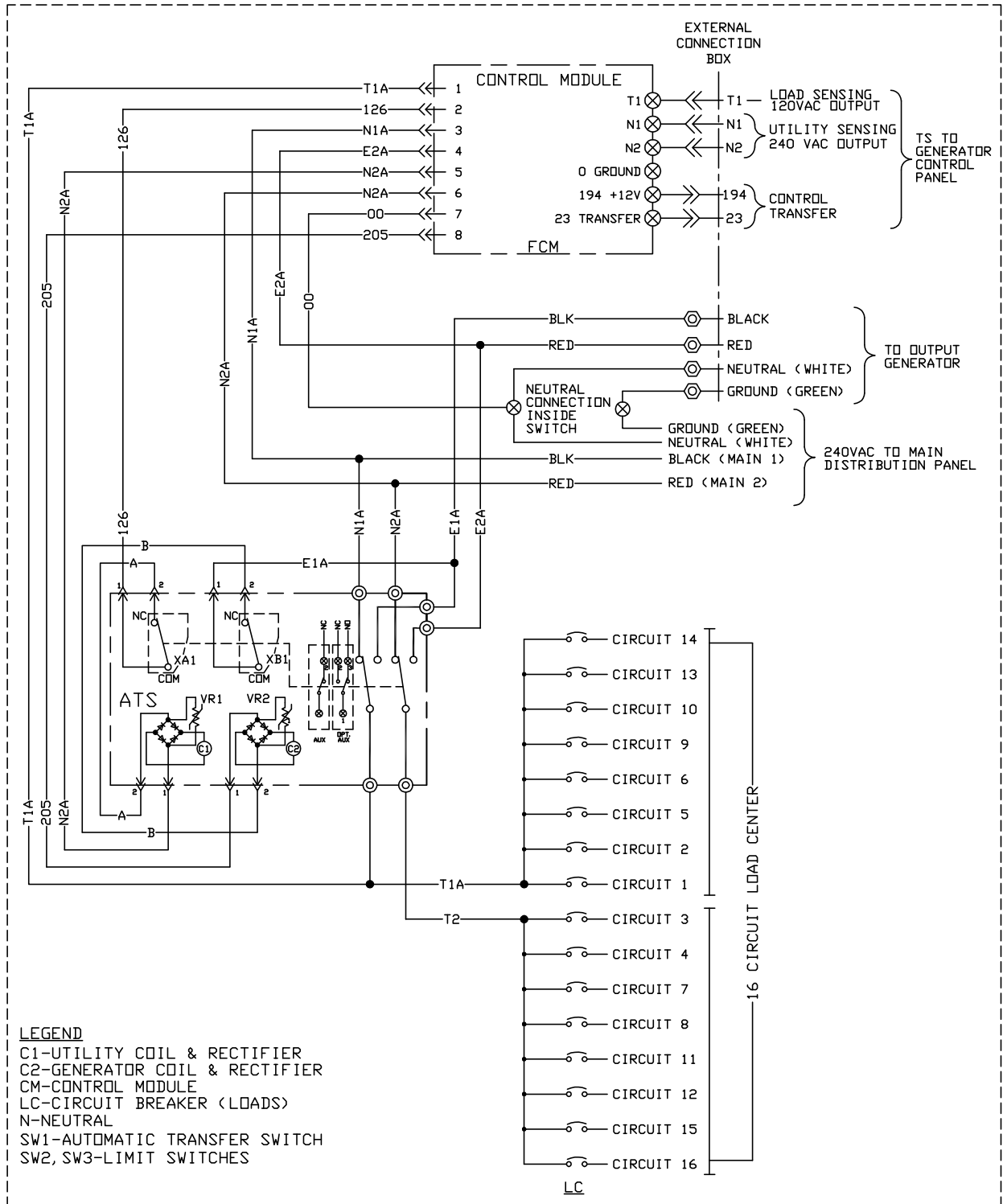

LEGEND

- C1-UTILITY COIL & RECTIFIER
- C2-GENERATOR COIL & RECTIFIER
- CM-CONTROL MODULE
- LC-CIRCUIT BREAKER (LOADS)
- N-NEUTRAL
- SW1-AUTOMATIC TRANSFER SWITCH
- SW2, SW3-LIMIT SWITCHES

REVISION:A
DATE: 6/27/17

SCHEMATIC - DIAGRAM
HSB TRANSFER SWITCH 100A
DRAWING #:10000018987

This page intentionally left blank.

Part No. 10000012944 Rev. B 07/26/2021

©2021 Generac Power Systems, Inc.
All rights reserved.
Specifications are subject to change without notice.
No reproduction allowed in any form without prior written consent
from Generac Power Systems, Inc.

GENERAC[®]



Generac Power Systems, Inc.
S45 W29290 Hwy. 59
Waukesha, WI 53189
1-888-GENERAC (1-888-436-3722)
www.generac.com